

With pneumatic and electric actuators

ARI-STEVI® 440 / 441

Pneumatic actuator

ARI-DP 32-34 Tri

- Reversible pneumatic actuator
- Actuator with rolling diaphragm
- Air supply pressure max. 6 bar
- Stem protection by bellow
- Maintenance-free O-ring sealing
- Assembly of additional devices acc. to DIN IEC 60534-6

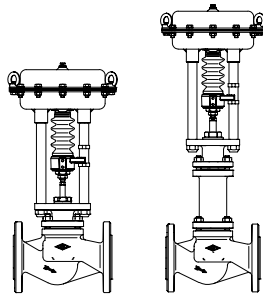

Page 4

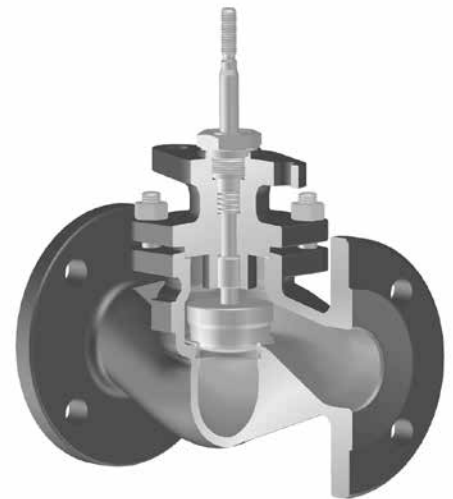

Fig. 440

ARI-STEVI® 440 / 441

Electric actuator

ARI-PREMIO 2,2-15kN

ARI-PREMIO-Plus 2G 2,2-15kN

- Enclosure IP 65
- 2 torque switches
- Handwheel
- Additional devices available, e.g. potentiometer

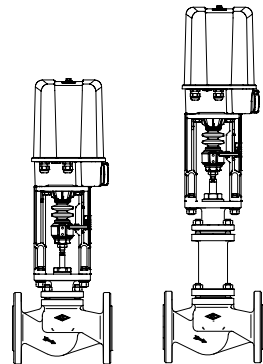

Page 12

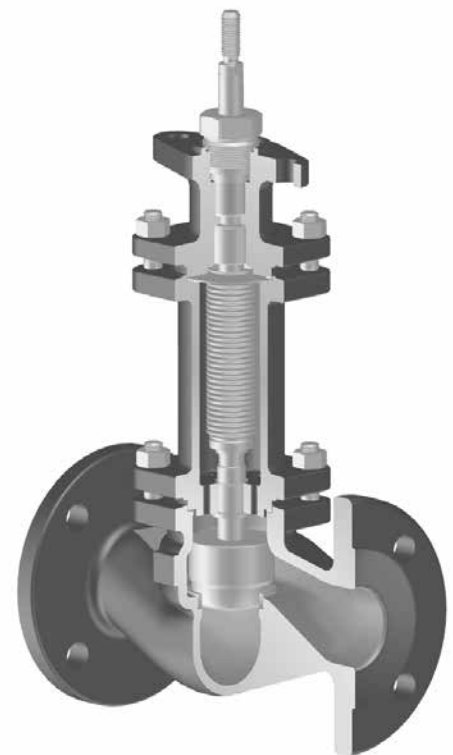

Fig. 441

ARI-STEVI® 440 / 441

Electric actuator

AUMA SAR 07.2-10.2

- Enclosure IP 67
- 2 torque switches
- 2 travel switches
- Handwheel
- Overheating protection for motor as standard
- Additional devices available, e.g. potentiometer
- Explosion proof version available

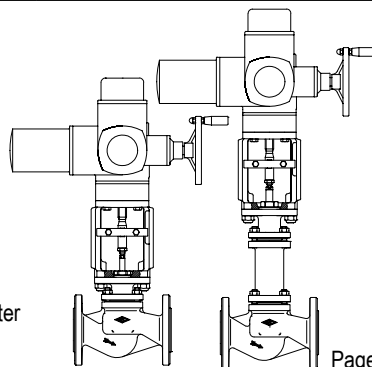

Page 14

ARI-STEVI® 440

Electric actuator with fail-safe function

FR1.2

- Operation mode for fail-safe function CLOSE
- Enclosure IP 66
- Operating time adjustable
- Additional devices available, e.g. potentiometer

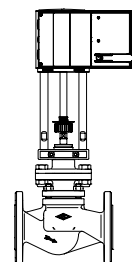

Page 16

ARI-STEVI® 440 / 441

Electric actuator with fail-safe function

FR2.1-2.2

- Type approval acc. to DIN 32730 for Fig. 440 with FR 2.1 
- Optional direction for safety reset, OPEN or CLOSE, as required
- Enclosure IP 54
- 1 travel switch for OPEN and CLOSE
- Additional devices available, e.g. potentiometer

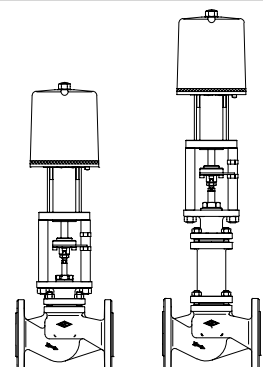

Page 18

Figure	Nominal pressure	Material	Nominal diameter	
12.440 / 12.441	PN16	EN-JL1040	DN15-250	Information / restriction of technical rules need to be observed! ARI-Valves of EN-JL1040 are not allowed to be operated in systems acc. to TRD 110. A production permission acc. to TRB 801 No. 45 is available. (acc. to TRB 801 No. 45 EN-JL1040 is not allowed.) The engineer, designing a system or a plant, is responsible for the selection of the correct valve. Resistance and fitness must be verified, contact manufacturer for information (refer to Product overview and Resistance list).
22.440 / 22.441	PN16	EN-JS1049	DN15-250	
23.440 / 23.441	PN25	EN-JS1049	DN15-150	
34.440 / 34.441	PN25	1.0619+N	DN15-250	
35.440 / 35.441	PN40	1.0619+N	DN15-250	
54.440 / 54.441	PN25	1.4408	DN15-250	
55.440 / 55.441	PN40	1.4408	DN15-150	
Other materials and versions on request.				

Stem sealing				
Fig. 440	standard		optional	
	DN15-150	DN200-250	DN15-250	DN15-250
	I. PTFE-V-ring unit -10°C to 220°C	II. PTFE-packing -10°C to 250°C	I. EPDM-sealing -10°C to 150°C (allowed for water and steam up to 180°C)	II. PTFE-packing -10°C to 250°C II. Pure graphite-packing -10°C to 450°C

Fig. 441	standard		optional	
	DN15-250		DN15-100	DN125-150
	III. Stainless steel-bellow with pure graphite-packing -60°C to 450°C		III. Stainless steel-bellow with V-ring unit -60°C to 220°C	III. Stainless steel bellows seal with EPDM-sealing -60°C to 150°C (allowed for water and steam up to 180°C)

Pressure-temperature-ratings Intermediate values for max. permissible operational pressures can be determined by linear interpolation of the given temperature / pressure chart.

acc. to DIN EN 1092-2			-60°C to <-10°C ¹⁾	-10°C to 120°C	150°C	200°C	250°C	300°C	350°C	400°C	450°C
EN-JL1040	PN16	(bar)	--	16	14,4	12,8	11,2	9,6	--	--	--
EN-JS1049	PN16	(bar)	on request	16	15,5	14,7	13,9	12,8	11,2	--	--
EN-JS1049	PN25	(bar)	on request	25	24,3	23	21,8	20	17,5	--	--

acc. to manufacturers standard			-60°C to <-10°C ¹⁾	-10°C to 120°C	150°C	200°C	250°C	300°C	350°C	400°C	450°C
1.0619+N	PN25	(bar)	18,7	25	23,9	22	20	17,2	16	14,8	8,2
1.0619+N	PN40	(bar)	30	40	38,1	35	32	28	25,7	23,8	13,1

acc. to DIN EN 1092-1			-60°C to <-10°C ¹⁾	-10°C to 100°C	150°C	200°C	250°C	300°C	350°C	400°C	450°C
1.4408	PN40	(bar)	40	40	36,3	33,7	31,8	29,7	28,5	27,4	--

¹⁾ Valve with extended bonnet, studs and nuts made of A4-70 (at temperatures below -10°C)

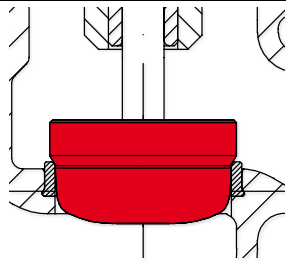
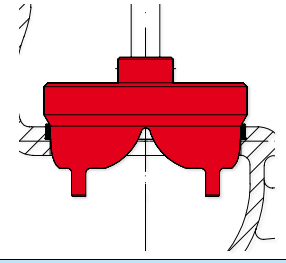
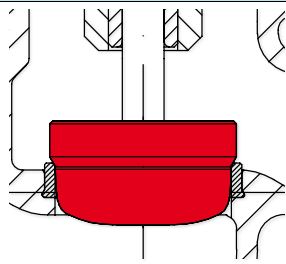
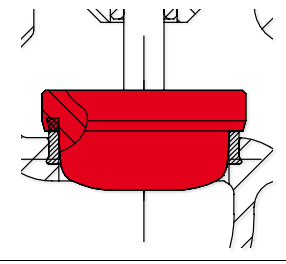
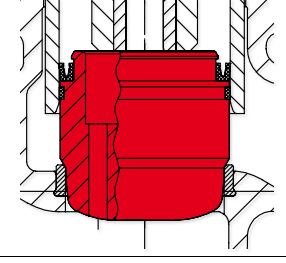
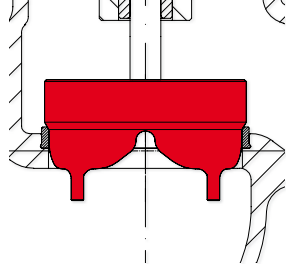
Plug design standard			Guiding	Rangeability
DN15-150: Parabolic plug, metal seat	<ul style="list-style-type: none"> - Leakage class IV acc. to DIN EN 60534-4 - Flow characteristic: <ul style="list-style-type: none"> - equal percentage (g/p) (from Kvs 100 modified) - linear (lin) 		Stem	50 : 1
DN200-250: V-port plug, metal seat	<ul style="list-style-type: none"> - Leakage class IV acc. to DIN EN 60534-4 - from Kvs 63 - Flow characteristic: <ul style="list-style-type: none"> - equal percentage (g/p) (from Kvs 100 modified) - linear (lin) 		Stem / Seat ring	30 : 1
Plug design optional			Guiding	Rangeability
DN15-150: Parabolic plug, tight closure	<ul style="list-style-type: none"> - Leakage class IV-S1 acc. to DIN EN 60534-4 (special actuator forces necessary, refer to separate data sheet) - Flow characteristic: <ul style="list-style-type: none"> - equal percentage (g/p) (from Kvs 100 modified) - linear (lin) 		Stem	50 : 1
DN15-150: Parabolic plug with PTFE-Soft seal (max. 200°C)	<ul style="list-style-type: none"> - Leakage class VI acc. to DIN EN 60534-4 - Flow characteristic: <ul style="list-style-type: none"> - equal percentage (g/p) (from Kvs 100 modified) - linear (lin) 		Stem	50 : 1
DN15-150: Parabolic plug with Pressure balanced plug metal seat Piston seal: PTFE with stainless steel spring (max. 200°C)	<ul style="list-style-type: none"> - Leakage class IV acc. to DIN EN 60534-4 - from Kvs 6,3 - Flow characteristic: <ul style="list-style-type: none"> - equal percentage (g/p) (from Kvs 100 modified) - linear (lin) 		Stem	50 : 1
DN65-150: V-port plug metal seat	<ul style="list-style-type: none"> - Leakage class IV acc. to DIN EN 60534-4 - from Kvs 63 - Flow characteristic: <ul style="list-style-type: none"> - equal percentage (g/p) (from Kvs 100 modified) - linear (lin) 		Stem / Seat ring	30 : 1

Control valve in straightway form with pneumatic actuator ARI-DP

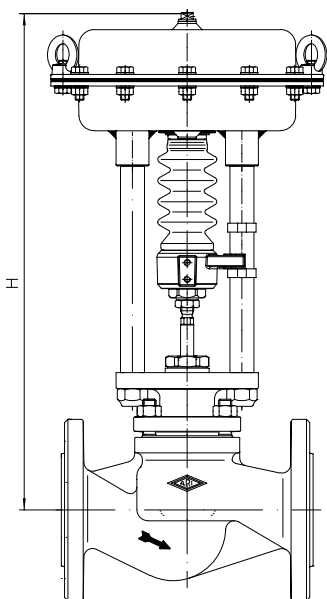

Fig. 440

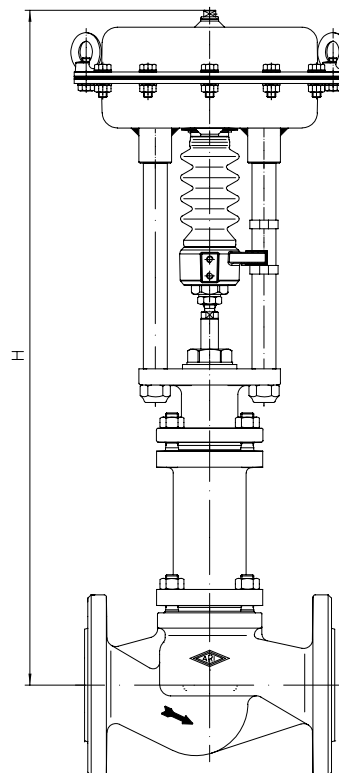
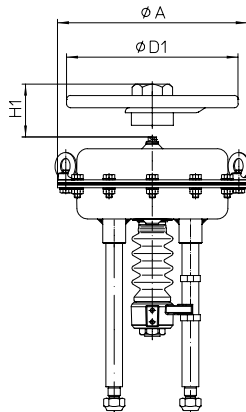

Fig. 441

Heights and weights

DN			15	20	25	32	40	50	65	80	100	125	150	200	250		
Fig. 440	DP32	H	(mm)	442	442	450	450	457	463	465	480	499	--	--	--	--	
		PN16	(kg)	13	13	14	16	18	21	26	31	42	--	--	--	--	--
		PN40	(kg)	13	14	15	17	19	22	29	35	48	--	--	--	--	--
	DP33	H	(mm)	497	497	505	505	512	518	531	546	565	--	--	--	--	--
		PN16	(kg)	19	19	20	22	24	27	32	37	48	--	--	--	--	--
		PN40	(kg)	19	20	21	23	25	28	35	41	54	--	--	--	--	--
	DP34	H	(mm)	--	--	--	--	--	--	666	681	680	719	779	841	901	
		PN16	(kg)	--	--	--	--	--	--	62	67	78	95	118	190	304	
		PN40	(kg)	--	--	--	--	--	--	65	71	84	101	122	222	336	
	DP34T	H	(mm)	--	--	--	--	--	--	--	--	--	--	--	1091	1151	
		PN16	(kg)	--	--	--	--	--	--	--	--	--	--	--	261	375	
		PN40	(kg)	--	--	--	--	--	--	--	--	--	--	--	293	407	
DP34Tri	H	(mm)	--	--	--	--	--	--	--	--	--	--	--	1313	1373		
	PN16	(kg)	--	--	--	--	--	--	--	--	--	--	--	295	409		
	PN40	(kg)	--	--	--	--	--	--	--	--	--	--	--	327	441		
Fig. 441	DP32	H	(mm)	627	627	635	635	626	628	701	713	729	--	--	--	--	
		PN16	(kg)	17	17	18	21	23	26	29	40	55	--	--	--	--	
		PN40	(kg)	19	21	23	26	32	35	42	52	68	--	--	--	--	
	DP33	H	(mm)	682	682	690	690	681	683	767	779	795	--	--	--	--	
		PN16	(kg)	23	23	24	27	29	32	35	46	61	--	--	--	--	
		PN40	(kg)	25	27	29	32	38	41	48	58	74	--	--	--	--	
	DP34	H	(mm)	--	--	--	--	--	--	902	914	930	1074	1105	1363	1427	
		PN16	(kg)	--	--	--	--	--	--	65	76	91	111	132	212	326	
		PN40	(kg)	--	--	--	--	--	--	78	88	104	121	138	247	362	
	DP34T	H	(mm)	--	--	--	--	--	--	--	--	--	--	--	1542	1601	
		PN16	(kg)	--	--	--	--	--	--	--	--	--	--	--	283	397	
		PN40	(kg)	--	--	--	--	--	--	--	--	--	--	--	318	433	
	DP34Tri	H	(mm)	--	--	--	--	--	--	--	--	--	--	--	1764	1823	
		PN16	(kg)	--	--	--	--	--	--	--	--	--	--	--	317	431	
		PN40	(kg)	--	--	--	--	--	--	--	--	--	--	--	352	467	

Other dimensions refer to pages 20-21.



DP32 / DP33 / DP34

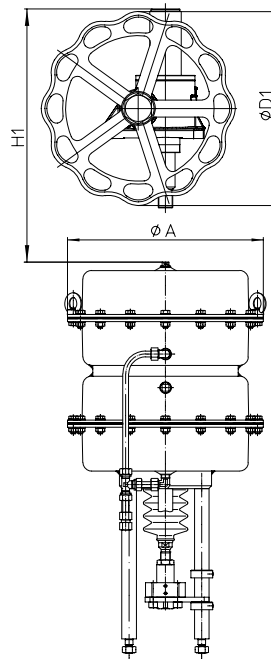

DP34T

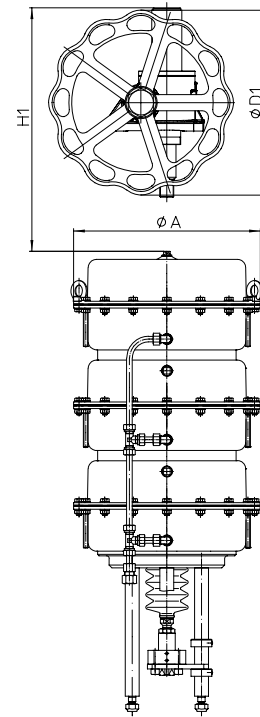



DP34Tri

Actuator data		DP32	DP33	DP34	DP34T	DP34Tri
Ø A	(mm)	250	300	405		
Effective diaphragm area	(cm ²)	250	400	800	1600	2400
Top mounted handwheel	Ø D1	(mm)	225	300	400	
	H1	(mm)	270	284	442	635
	Weight	(kg)	5		17	41

Technical data for actuator refer to data sheet ARI-DP.

max. permissible closing pressures on flow-to-open P2 = 0.
Observe pressure-temperature-limits, refer to page 2.

DN			15	20	25	32	40	50	65	80	100		
Parabolic plug	Kvs-value		(m ³ /h)	4 2,5	6,3 4 / 2,5	10 6,3	16 10	25 16	40 25	63 40	100 63	160 100	
	max. diff. pressure ¹⁾		(bar)	40	40	40	40	30	20	8	4	1,5	
V-port plug	Kvs-value		(m ³ /h)	--	--	--	--	--	--	63	100	160	
	max. diff. pressure ¹⁾		(bar)	--	--	--	--	--	--	30	25	25	
Seat-ø			(mm)	21	21	27	31	41	51	66	81	101	
Travel			(mm)	20						30			
DP32 250 cm² Spring closes on air failure  (extended through spring)	Spring range (bar)	0,2-1,0	1,2	I.	(bar)	5,5	5,5	2,6	1,6				
				II.	(bar)	2,3	2,3						
				III.	(bar)								
		0,4-1,2	1,4	I.	(bar)	18,6	18,6	10,7	7,8	3,9	2,2		
				II.	(bar)	15,4	15,4	8,7	6,2	3	1,6		
				III.	(bar)	8,6	8,6	7,1	5	1,7			
	0,8-2,4	2,7	I.	(bar)	40	40	26,8	20,1	11	6,8	3,7	2,2	1,2
			II.	(bar)	40	40	24,8	18,6	10,2	6,3	3,2	1,9	1
			III.	(bar)	26,4	26,4	23,2	17,3	8,9	5,4	2,9	1,7	
	1,5-2,9	3,2	I.	(bar)			40	40	23,5	15			
			II.	(bar)			40	40	22,7	14,4			
			III.	(bar)	40	40	40	38,9	21,4	13,6			
2,0-3,8	4,1	I.	(bar)					32,5	20,8				
		II.	(bar)					31,6	20,2				
		III.	(bar)				40	30,3	19,4				

DN			15	20	25	32	40	50	65	80	100		
Parabolic plug	Kvs-value		(m ³ /h)	4 2,5	6,3 4 / 2,5	10 6,3	16 10	25 16	40 25	63 40	100 63	160 100	
	max. diff. pressure ¹⁾		(bar)	40	40	40	40	30	20	8	4	1,5	
V-port plug	Kvs-value		(m ³ /h)	--	--	--	--	--	--	63	100	160	
	max. diff. pressure ¹⁾		(bar)	--	--	--	--	--	--	30	25	25	
Seat-ø			(mm)	21	21	27	31	41	51	66	81	101	
Travel			(mm)	20						30			
DP32 250 cm² Spring opens on air failure  (retracted through spring)	Air supply pressure min. (bar) ²⁾	1,4	I.	(bar)	18,6	18,6	10,7	7,8	3,9	2,2			
			II.	(bar)	15,4	15,4	8,7	6,2	3	1,6			
			III.	(bar)	8,6	8,6	7,1	5	1,7				
		2	I.	(bar)	40	40	34,9	26,3	14,6	9,2	5	3,1	1,8
			II.	(bar)	40	40	32,9	24,8	13,7	8,6	4,6	2,8	1,6
			III.	(bar)	35,2	35,2	31,3	23,5	12,4	7,7	4,3	2,6	1,5
		3	I.	(bar)			40	40	32,5	20,8	12	7,8	4,8
			II.	(bar)			40	40	31,6	20,2	11,6	7,5	4,6
			III.	(bar)	40	40	40	40	30,3	19,4	11,3	7,3	4,5
		4	I.	(bar)					40	32,4	19	12,4	7,8
			II.	(bar)					40	31,8	18,6	12,1	7,6
			III.	(bar)					40	31	18,3	11,9	7,5
		5	I.	(bar)						40	26	17	10,8
			II.	(bar)						40	25,6	16,7	10,6
			III.	(bar)						40	25,3	16,5	10,5
		6	I.	(bar)							33	21,7	13,8
			II.	(bar)							32,6	21,4	13,6
			III.	(bar)							32,3	21,2	13,5

I. Fig. 440: PTFE-V-ring unit / EPDM-sealing

II. Fig. 440: PTFE- / pure graphite-packing

III. Fig. 441: Bellows seal

¹⁾ max. differential pressure drop

²⁾ Air supply pressure max. to actuator: 6 bar Restriction: a) 5 bar b) 4,5 bar c) 4 bar d) 3,5 bar e) 3 bar

max. permissible closing pressures on flow-to-open P2 = 0.
Observe pressure-temperature-limits, refer to page 2.

DN			15	20	25	32	40	50	65	80	100				
Parabolic plug	Kvs-value	(m ³ /h)	4 2,5	6,3 4 / 2,5	10 6,3	16 10	25 16	40 25	63 40	100 63	160 100				
	max. diff. pressure ¹⁾	(bar)	40	40	40	40	30	20	8	4	1,5				
V-port plug	Kvs-value	(m ³ /h)	--	--	--	--	--	--	63	100	160				
	max. diff. pressure ¹⁾	(bar)	--	--	--	--	--	--	30	25	25				
Seat-ø		(mm)	21	21	27	31	41	51	66	81	101				
Travel		(mm)	20						30						
DP33 400 cm² Spring closes on air failure  (extended through spring)	Spring range (bar)	Air supply pressure min. (bar) ²⁾	1,2	I.	(bar)	13,3 c)	13,3 c)	7,4c)	5,2 c)	2,4 c)	1,2 c)				
				II.	(bar)	10,1 c)	10,1 c)	5,4 c)	3,7 c)	1,5 c)					
				III.	(bar)	5 a)	5 a)	3,8 a)	2,5 a)						
			1,4	I.	(bar)	34,2 c)	34,2 c)	20,2 c)	15,1 c)	8,1 c)	4,9 c)	2,5	1,4		
				II.	(bar)	31 c)	31 c)	18,3 c)	13,6 c)	7,3 c)	4,4 c)	2,1	1,1		
				III.	(bar)	19,1 a)	19,1 a)	16,6 a)	12,3 a)	5,9 a)	3,5 a)	1,8 a)			
	2,7	I.	(bar)	40 a)	40 a)	40 a)	34,7 a)	19,5 a)	12,3 a)	7	4,4	2,6			
		II.	(bar)	40 a)	40 a)	40 a)	33,2 a)	18,6 a)	11,8 a)	6,5	4,1	2,4			
		III.	(bar)	40	40	40	31,9	17,3	10,9	6,2	3,9	2,3			
	3,3	I.	(bar)							14,8	9,6	6			
		II.	(bar)							14,3	9,3	5,8			
		III.	(bar)							14	9,1	5,7			
	3,1	I.	(bar)				40 a)	40 a)	29 a)						
		II.	(bar)				40 a)	40 a)	28,4 a)						
		III.	(bar)				40	40	27,6						
	4,5	I.	(bar)							20,3	13,3	8,4			
		II.	(bar)							19,9	12,9	8,2			
		III.	(bar)							19,6	12,8	8,1			
	4,5	I.	(bar)					40							
		II.	(bar)						39,5						
		III.	(bar)						38,6						

DN			15	20	25	32	40	50	65	80	100			
Parabolic plug	Kvs-value	(m ³ /h)	4 2,5	6,3 4 / 2,5	10 6,3	16 10	25 16	40 25	63 40	100 63	160 100			
	max. diff. pressure ¹⁾	(bar)	40	40	40	40	30	20	8	4	1,5			
V-port plug	Kvs-value	(m ³ /h)	--	--	--	--	--	--	63	100	160			
	max. diff. pressure ¹⁾	(bar)	--	--	--	--	--	--	30	25	25			
Seat-ø		(mm)	21	21	27	31	41	51	66	81	101			
Travel		(mm)	20						30					
DP33 400 cm² Spring opens on air failure  (retracted through spring)	Air supply pressure min. (bar) ²⁾	1,4	I.	(bar)	34,2 d)	34,2 d)	20,2 d)	15,1 d)	8,1 d)	4,9 d)	2,5 d)	1,4 d)		
			II.	(bar)	31 d)	31 d)	18,3 d)	13,6 d)	7,3 d)	4,4 d)	2,1 d)	1,1 d)		
			III.	(bar)	19,1 d)	19,1 d)	16,6 d)	12,3 d)	5,9 d)	3,5 d)	1,8 d)			
		2	I.	(bar)	40 d)	40 d)	40 d)	40 d)	25,2 d)	16 d)	9,2 d)	5,9 d)	3,6 d)	
			II.	(bar)	40 d)	40 d)	40 d)	40 d)	24,3 d)	15,5 d)	8,7 d)	5,6 d)	3,4 d)	
			III.	(bar)	40 d)	40 d)	40 d)	40 d)	23 d)	14,6 d)	8,4 d)	5,4 d)	3,3 d)	
		3	I.	(bar)					40 d)	34,6 d)	20,3 d)	13,3 d)	8,4 d)	
			II.	(bar)					40 d)	34 d)	19,9 d)	12,9 d)	8,2 d)	
			III.	(bar)					40 d)	33,1 d)	19,6 d)	12,8 d)	8,1 d)	
		4	I.	(bar)						40 c)	31,4	20,6	13,1	
			II.	(bar)						40 c)	31	20,3	12,9	
			III.	(bar)						40 a)	30,7 a)	20,1 a)	12,8 a)	
		5	I.	(bar)							40	28	17,9	
			II.	(bar)							40	27,7	17,7	
			III.	(bar)							40 a)	27,5 a)	17,6 a)	
		6	I.	(bar)								35,4	22,7	
			II.	(bar)								35,1	22,5	

- I. Fig. 440: PTFE-V-ring unit / EPDM-sealing
 II. Fig. 440: PTFE- / pure graphite-packing
 III. Fig. 441: Bellows seal

¹⁾ max. differential pressure drop

²⁾ Air supply pressure max. to actuator: 6 bar Restriction: a) 5 bar b) 4,5 bar c) 4 bar d) 3,5 bar e) 3 bar

max. permissible closing pressures on flow-to-open P2 = 0.
Observe pressure-temperature-limits, refer to page 2.

DN			65	80	100	125	150	200	250		
Parabolic plug	Kvs-value		(m ³ /h)	63	100	160	250	400	--	--	
	max. diff. pressure ¹⁾		(bar)	8	4	1,5	1	1	--	--	
V-port plug	Kvs-value		(m ³ /h)	63	100	160	250	400	630	1000	
	max. diff. pressure ¹⁾		(bar)	30	25	25	10	10	5	5	
Seat-ø			(mm)	66	81	101	126	151	201	251	
Travel			(mm)	30			50		65		
DP34 800 cm ² Spring closes on air failure  (extended through spring)	Spring range (bar)	0,2-1,0	1,2	I.	(bar)	2,5 b)	1,5 b)				
				II.	(bar)	2,1 b)	1,2 b)				
				III.	(bar)	1,8 e)	1 e)				
		0,4-1,2	1,4	I.	(bar)	7 b)	4,4 b)	2,7 b)	1,6	1	
				II.	(bar)	6,6 b)	4,1 b)	2,5 b)	1,4		
				III.	(bar)	6,3 d)	3,9 d)	2,3 d)	1,2 a)		
	0,8-2,4	2,7	I.	(bar)	16	10,4	6,5	4	2,7		
			II.	(bar)	15,5	10,1	6,3	3,9	2,6		
			III.	(bar)	15,2 b)	9,9 b)	6,2 b)	3,7	2,5		
	1,0-2,0	2,4	I.	(bar)						1,9	1,1
			II.	(bar)						1,8	1,1
			III.	(bar)						1,7	1
	1,5-3,0	3,3	I.	(bar)				8,4	5,7		
			II.	(bar)				8,2	5,6		
			III.	(bar)				8,1	5,5		
	2,0-4,0	4,5	I.	(bar)				11,5	7,9	4,3	2,7
			II.	(bar)				11,3	7,8	4,2	2,6
			III.	(bar)				11,2	7,7	4,2	2,6
2,1-3,0	3,3	I.	(bar)	40	29,7	19					
		II.	(bar)	40	29,4	18,8					
		III.	(bar)	40 a)	29,2 a)	18,7 a)					
2,4-3,6	4,5	I.	(bar)								
		II.	(bar)								

DN			65	80	100	125	150	200	250			
Parabolic plug	Kvs-value		(m ³ /h)	63	100	160	250	400	--	--		
	max. diff. pressure ¹⁾		(bar)	8	4	1,5	1	1	--	--		
V-port plug	Kvs-value		(m ³ /h)	63	100	160	250	400	630	1000		
	max. diff. pressure ¹⁾		(bar)	30	25	25	10	10	5	5		
Seat-ø			(mm)	66	81	101	126	151	201	251		
Travel			(mm)	30			50		65			
DP34 800 cm ² Spring opens on air failure  (retracted through spring)	Air supply pressure min. (bar) ²⁾	1,4	I.	(bar)	7 b)	4,4 b)	2,7 b)	1,6	1			
				II.	(bar)	6,6 b)	4,1 b)	2,5 b)	1,4			
				III.	(bar)	6,3 e)	3,9 e)	2,3 e)	1,2 a)			
		2	I.	(bar)	20,5 b)	13,3 b)	8,4 b)	5,3	3,6	1,9	1,1	
				II.	(bar)	20 b)	13 b)	8,2 b)	5,1	3,5	1,8	1,1
				III.	(bar)	19,7 e)	12,9 e)	8,1 e)	5 a)	3,4 a)	1,7 a)	1 a)
	3	I.	(bar)	40 b)	28,2 b)	18 b)	11,5	7,9	4,3	2,7		
			II.	(bar)	40 b)	27,9 b)	17,8 b)	11,3	7,8	4,2	2,6	
			III.	(bar)	40 e)	27,7 e)	17,7 e)	11,2 a)	7,7 a)	4,2 a)	2,6 a)	
	4	I.	(bar)		40 b)	27,6 b)	17,7	12,2	6,8	4,3		
			II.	(bar)		40 b)	27,5 b)	17,5	12,1	6,7	4,2	
			III.	(bar)				17,4 a)	12 a)	6,6 a)	4,2 a)	
	5	I.	(bar)				23,9	16,6	9,2	5,8		
			II.	(bar)			23,7	16,5	9,1	5,8		
			III.	(bar)			23,6 a)	16,3 a)	9,1 a)	5,8 a)		
	6	I.	(bar)				30,9	20,9	11,7	7,4		
			II.	(bar)				29,9	20,8	11,6	7,4	

I. Fig. 440: PTFE-V-ring unit (DN15-150) / EPDM-sealing

II. Fig. 440: PTFE- / pure graphite-packing

III. Fig. 441: Bellows seal

¹⁾ max. differential pressure drop

²⁾ Air supply pressure max. to actuator: 6 bar Restriction: a) 5 bar b) 4,5 bar c) 4 bar d) 3,5 bar e) 3 bar

max. permissible closing pressures on flow-to-open P2 = 0.
 Observe pressure-temperature-limits, refer to page 2.

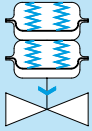
DN						200	250	
V-port plug	Kvs-value				(m ³ /h)	630	1000	
	max. diff. pressure ¹⁾				(bar)	5	5	
Seat-ø					(mm)	201	251	
Travel					(mm)	65		
DP34T 1600 cm² Spring closes on air failure  (extended through spring)	Spring range (bar)	0,4-1,2	Air supply pressure min. (bar) ²⁾	1,7	I.	(bar)	1,4 b)	
					II.	(bar)	1,3 b)	
					III.	(bar)	1,2 d)	
	1,0-2,0	2,5		I.	(bar)	4,3 a)	2,7 a)	
				II.	(bar)	4,2 a)	2,6 a)	
				III.	(bar)	4,2 c)	2,6 c)	
	2,0-4,0	4,5	I.	(bar)	9,2	5,8		
			II.	(bar)	9,1	5,8		
			III.	(bar)	9,1	5,8		

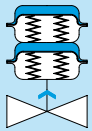
DN						200	250	
V-port plug	Kvs-value				(m ³ /h)	630	1000	
	max. diff. pressure ¹⁾				(bar)	5	5	
Seat-ø					(mm)	201	251	
Travel					(mm)	65		
DP34T 1600 cm² Spring opens on air failure  (retracted through spring)	Air supply pressure min. (bar) ²⁾	1,5		I.	(bar)	1,9 b)	1,1 b)	
					II.	(bar)	1,8 b)	1,1 b)
					III.	(bar)	1,7 e)	1 e)
		2		I.	(bar)	4,3 b)	2,7 b)	
					II.	(bar)	4,2 b)	2,6 b)
					III.	(bar)	4,2 e)	2,6 e)
		3		I.	(bar)	9,2 b)	5,8 b)	
					II.	(bar)	9,1 b)	5,8 b)
					III.	(bar)	9,1 e)	5,8 e)
		4		I.	(bar)	14,1 b)	9 b)	
					II.	(bar)	14 b)	8,9 b)
		4,5		I.	(bar)	16,6 b)	10,6 b)	
					II.	(bar)	16,5 b)	10,5 b)

- I. Fig. 440: EPDM-sealing
- II. Fig. 440: PTFE- / pure graphite-packing
- III. Fig. 441: Bellows seal

¹⁾ max. differential pressure drop

²⁾ Air supply pressure max. to actuator: 6 bar Restriction: a) 5 bar b) 4,5 bar c) 4 bar d) 3,5 bar e) 3 bar

max. permissible closing pressures on flow-to-open P2 = 0.
Observe pressure-temperature-limits, refer to page 2.

DN						200	250	
V-port plug	Kvs-value		(m³/h)			630	1000	
	max. diff. pressure ¹⁾		(bar)			5	5	
Seat-ø			(mm)			201	251	
Travel			(mm)			65		
<p>DP34Tri 2400 cm² Spring closes on air failure</p> <p>(extended through spring)</p>	Spring range (bar)	0,4-1,2	Air supply pressure min. (bar) ²⁾	1,7	I.	(bar)	2,4 d)	1,4 d)
					II.	(bar)	2,3 d)	1,4 d)
					III.	(bar)	2,2 f)	1,4 f)
		1,0-2,0		2,5	I.	(bar)	6,8 b)	4,3 b)
					II.	(bar)	6,7 b)	4,2 b)
					III.	(bar)	6,6 d)	4,2 d)
	1,5-3,0	3,5	I.	(bar)	10,4 a)	6,6 a)		
			II.	(bar)	10,3 a)	6,6 a)		
			III.	(bar)	10,3 b)	6,5 b)		
	2,0-4,0	4,5	I.	(bar)	14,1	9		
			II.	(bar)	14	8,9		

- I. Fig. 440: EPDM-sealing
- II. Fig. 440: PTFE- / pure graphite-packing
- III. Fig. 441: Bellows seal

¹⁾ max. differential pressure drop

²⁾ Air supply pressure max. to actuator: 5 bar Restriction: a) 5 bar b) 4,5 bar c) 4 bar d) 3,5 bar e) 3 bar

Control valve in straightway form with electric actuator ARI-PREMIO

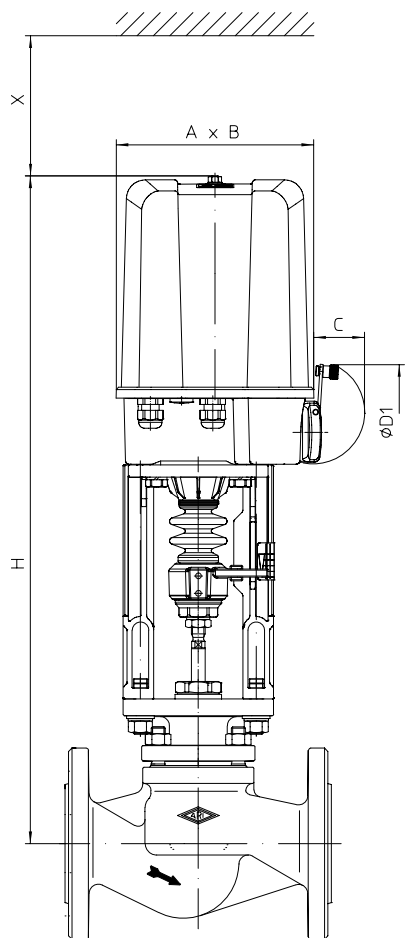

Fig. 440

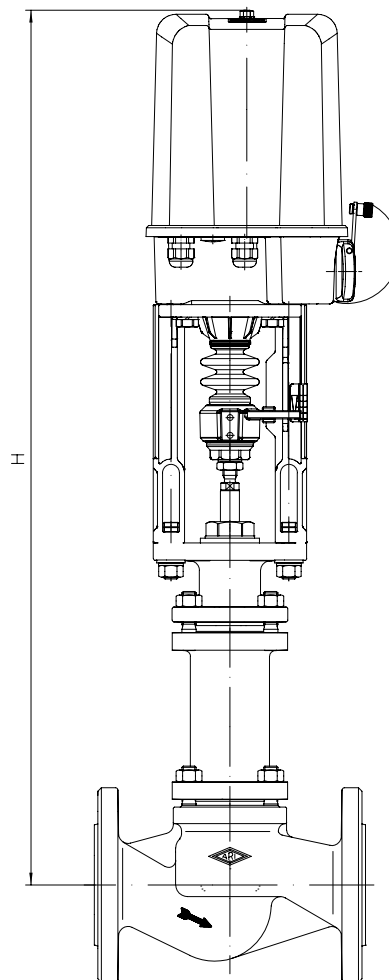

Fig. 441

Actuator data		2,2 - 5 kN	12 - 15 kN
A	(mm)	171	210
B	(mm)	156	184
C	(mm)	50	97
Ø D1	(mm)	90	130
X	(mm)	150	200

Supply voltage: 230V 50Hz
Other voltages: 24V 50/60Hz; 115V 50/60Hz; 230V 60Hz
Technical data for actuator refer to data sheet ARI-PREMIO/PREMIO-Plus 2G

Heights and weights

DN	15	20	25	32	40	50	65	80	100	125	150	200	250			
Fig. 440	2,2 kN	H	(mm)	550	550	558	558	565	571	584	599	618	--	--	--	--
		PN16	(kg)	9	10	11	12	14	17	22	28	38	--	--	--	--
		PN40	(kg)	10	11	12	13	15	18	25	31	44	--	--	--	--
	5 kN	H	(mm)	550	550	558	558	565	571	584	599	618	690	750	--	--
		PN16	(kg)	--	--	12	13	15	18	23	29	39	56	79	--	--
		PN40	(kg)	--	--	13	14	17	20	27	33	45	62	84	--	--
	12 kN	H	(mm)	--	--	--	--	740	746	759	774	793	832	892	1008	1068
		PN16	(kg)	--	--	--	--	19	22	27	33	43	60	83	155	270
		PN40	(kg)	--	--	--	--	21	24	31	37	49	66	88	187	302
Fig. 441	2,2 kN	H	(mm)	735	735	743	743	734	736	820	832	848	--	--	--	--
		PN16	(kg)	13	13	14	17	19	22	25	36	51	--	--	--	--
		PN40	(kg)	15	17	19	22	28	31	38	48	64	--	--	--	--
	5 kN	H		735	735	743	743	734	736	820	832	848	1045	1076	--	--
		PN16	(kg)	15	15	16	18	21	23	26	37	53	72	94	--	--
		PN40	(kg)	17	18	21	24	30	32	39	49	66	83	99	--	--
	12 kN	H	(mm)	--	--	--	--	909	911	995	1007	1023	1187	1218	1429	1493
		PN16	(kg)	--	--	--	--	25	27	30	41	57	76	89	179	293
		PN40	(kg)	--	--	--	--	34	36	43	53	70	87	103	214	329

Other dimensions refer to pages 20-21.

max. permissible closing pressures on flow-to-open P2 = 0.
Observe pressure-temperature-limits, refer to page 2.

DN			15	20	25	32	40	50	65	80	100	125	150	200	250	
Parabolic plug	Kvs-value	(m ³ /h)	4 2,5	6,3 4 / 2,5	10 6,3	16 10	25 16	40 25	63 40	100 63	160 100	250 160	400 250	--	--	
	max. diff. pressure ¹⁾	(bar)	40	40	40	40	30	20	8	4	1,5	1	1	--	--	
V-port plug	Kvs-value	(m ³ /h)	--	--	--	--	--	--	63	100	160	250	400	630	1000	
	max. diff. pressure ¹⁾	(bar)	--	--	--	--	--	--	30	25	25	10	10	5	5	
Seat-Ø		(mm)	21	21	27	31	41	51	66	81	101	126	151	201	251	
Travel		(mm)	20						30			50		65		
2,2 kN	Closing pressure	I.	(bar)	40	40	30,8	23,1	12,8	8	4,3	2,7	1,5				
		II.	(bar)	40	40	28,8	21,6	11,9	7,4	3,9	2,3	1,3				
		III.	(bar)	30,7	30,7	27,1	20,4	10,6	6,5	3,6	2,2	1,2				
	Operating time (50 Hz)	(s)	53						79							
Operating speed	(mm/s)	0,38														
5 kN	Closing pressure	I.	(bar)			40	40	33,2	21,3	12,3	8	4,9	3	2		
		II.	(bar)			40	40	32,3	20,7	11,9	7,6	4,7	2,9	1,9		
		III.	(bar)	40	40	40	40	31	19,8	11,6	7,5	4,6	2,7	1,8		
	Operating time (50 Hz)	(s)	53						79			132				
Operating speed	(mm/s)	0,38														
12 kN	Closing pressure	I.	(bar)					40	40	32,3	21,2	13,5	8,5	5,9	3,2	2
		II.	(bar)					40	40	31,8	20,9	13,3	8,4	5,8	3,1	1,9
		III.	(bar)					40	40	31,6	20,7	13,2	8,2	5,6	3	1,9
	Operating time (50 Hz)	(s)						53	79			132		171		
Operating speed	(mm/s)	0,38														
15 kN	Closing pressure	I.	(bar)							40	26,9	17,2	10,9	7,5	4,1	2,6
		II.	(bar)							40	26,6	17	10,8	7,4	4	2,5
		III.	(bar)							40	26,4	16,9	10,6	7,3	4	2,5
	Operating time (50 Hz)	(s)								79			132		171	
Operating speed	(mm/s)	0,38														

I. Fig. 440: PTFE-V-ring unit (DN15-150) / EPDM-sealing

II. Fig. 440: PTFE- / pure graphite-packing

III. Fig. 441: Bellows seal

¹⁾ max. differential pressure drop

Control valve in straightway form with electric actuator AUMA

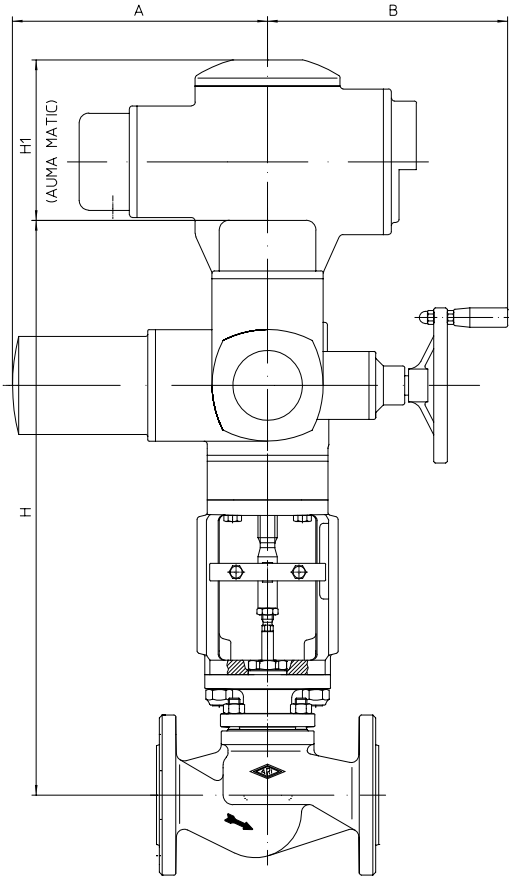

Fig. 440

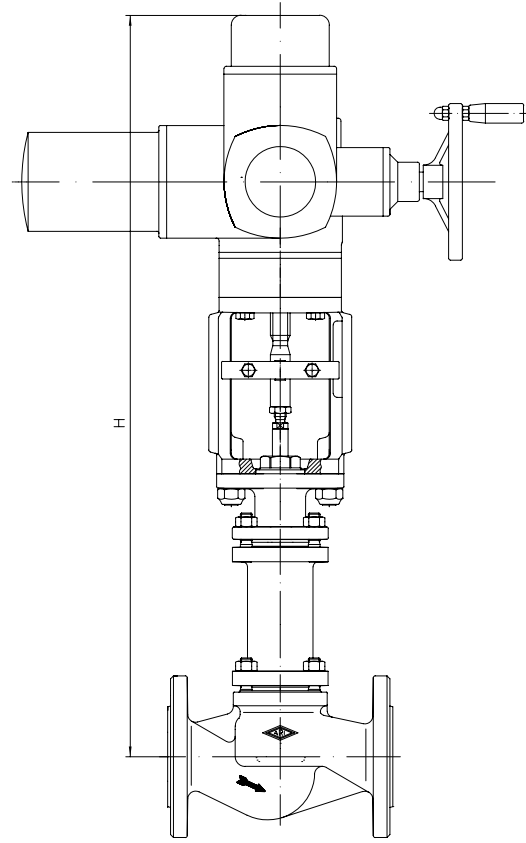

Fig. 441

Actuator data		SAR 07.2	SAR 07.6	SAR 10.2
A	(mm)	265		283
B	(mm)	249		254
H1 (AUMA MATIC)	(mm)	130		

Supply voltage: 400V 50Hz 3~ (Other voltages on request)
 Technical data for actuator refer to price list.

Heights and weights

DN			40	50	65	80	100	125	150	200	250	
Fig. 440	SAR 07.2	H	(mm)	611	617	630	645	664	703	763	--	--
		PN16	(kg)	36	39	44	50	60	77	100	--	--
		PN40	(kg)	37	40	47	53	66	83	105	--	--
	SAR 07.6	H	(mm)	--	617	630	645	664	703	763	844	904
		PN16	(kg)	--	40	46	51	61	79	102	178	292
		PN40	(kg)	--	42	49	55	68	85	106	210	324
	SAR 10.2	H	(mm)	--	--	642	657	676	715	775	856	916
		PN16	(kg)	--	--	48	54	64	81	104	180	295
		PN40	(kg)	--	--	51	57	70	87	109	212	327
Fig. 441	SAR 07.2	H	(mm)	780	782	866	878	894	1058	1089	--	--
		PN16	(kg)	41	44	47	58	73	93	114	--	--
		PN40	(kg)	50	53	60	70	86	104	120	--	--
	SAR 07.6	H	(mm)	--	782	866	878	894	1058	1089	1289	1301
		PN16	(kg)	--	45	48	59	75	95	116	201	315
		PN40	(kg)	--	54	61	71	88	105	122	236	351
	SAR 10.2	H	(mm)	--	--	--	--	--	1070	1101	1349	1361
		PN16	(kg)	--	--	--	--	--	97	118	203	318
		PN40	(kg)	--	--	--	--	--	108	124	239	353

For version with AUMA SAR Ex other heights.

Other dimensions refer to pages 20-21.

max. permissible closing pressures on flow-to-open P2 = 0.
 Observe pressure-temperature-limits, refer to page 2.

Fig. 440

DN				40	50	65	80	100	125	150	200	250
Parabolic plug	Kvs-value		(m ³ /h)	25 16	40 25	63 40	100 63	160 100	250 160	400 250	--	--
	max. diff. pressure ¹⁾		(bar)	30	20	8	4	1,5	1	1	--	--
V-port plug	Kvs-value		(m ³ /h)	--	--	63	100	160	250	400	630	1000
	max. diff. pressure ¹⁾		(bar)	--	--	30	25	25	10	10	5	5
Seat-Ø			(mm)	41	51	66	81	101	126	151	201	251
Travel			(mm)	20		30		50		65		
SAR 07.2 Output drive Form A TR 20 x 4 - LH	Closing pressure	shut off	I./II. (bar)	40	40	40	29,7	19	12,1	8,3		
		controlling ²⁾	I./II. (bar)	40	36,5	21,4	14	8,8	5,5	3,7		
	Torque		(Nm)	15	20	30	30	30	30	30		
	Operating time (50 Hz)		(s)	54		56		94				
Output drive		(rpm)	5,6		8		8					
SAR 07.6 Output drive Form A TR 26 x 5 - LH	Closing pressure	shut off	I./II. (bar)		40	40	40	26,9	17,2	11,9	6,5	4,1
		controlling ²⁾	I./II. (bar)		40	30,5	20	12,8	8	5,5	2,9	1,8
	Torque		(Nm)		30	40	60	60	60	60	60	60
	Operating time (50 Hz)		(s)		43	64		55		71		
Output drive		(rpm)		5,6	5,6		11		11			
SAR 10.2 Output drive Form A TR 26 x 5 - LH	Closing pressure	shut off	I./II. (bar)			40	40	31,6	29,3	20,3	13,7	8,7
		controlling ²⁾	I./II. (bar)			40	40	26,9	17,2	11,9	6,5	4,1
	Torque		(Nm)			60	60	70	100	100	120	120
	Operating time (50 Hz)		(s)			64		55		71		
Output drive		(rpm)			5,6		11		11			

Fig. 441

DN				40	50	65	80	100	125	150	200	250
Parabolic plug	Kvs-value		(m ³ /h)	25 16	40 25	63 40	100 63	160 100	250 160	400 250	--	--
	max. diff. pressure ¹⁾		(bar)	30	20	8	4	1,5	1	1	--	--
V-port plug	Kvs-value		(m ³ /h)	--	--	63	100	160	250	400	630	1000
	max. diff. pressure ¹⁾		(bar)	--	--	30	25	25	10	10	5	5
Seat-Ø			(mm)	41	51	66	81	101	126	151	201	251
Travel			(mm)	20		30		50		65		
SAR 07.2 Output drive Form A TR 20 x 4 - LH	Closing pressure	shut off	III. (bar)	40	40	40	29,5	18,9	11,9	8,2		
		controlling ²⁾	III. (bar)	40	35,7	21,1	13,8	8,7	5,3	3,6		
	Torque		(Nm)	15	20	30	30	30	30	30		
	Operating time (50 Hz)		(s)	54		56		94				
Output drive		(rpm)	5,6		8		8					
SAR 07.6 Output drive Form A TR 26 x 5 - LH	Closing pressure	shut off	III. (bar)		40	40	30,8	19,7	17	11,7	6,5	4,1
		controlling ²⁾	III. (bar)		40	30,2	19,8	12,6	7,9	5,4	2,9	1,8
	Torque		(Nm)		30	40	45	45	60	60	60	60
	Operating time (50 Hz)		(s)		43	64		55		71		
Output drive		(rpm)		5,6	5,6		11		11			
SAR 10.2 Output drive Form A TR 26 x 5 - LH	Closing pressure	shut off	III. (bar)						26,1	18,1	10,1	6,4
		controlling ²⁾	III. (bar)						17	11,7	6,5	4,1
	Torque		(Nm)						90	90	90	90
	Operating time (50 Hz)		(s)						55		71	
Output drive		(rpm)						11		11		

I. Fig. 440: PTFE-V-ring unit (DN15-150) / EPDM-sealing

II. Fig. 440: PTFE- / pure graphite-packing

III. Fig. 441: Bellows seal

¹⁾ max. differential pressure drop

²⁾ Restrictions through max. permissible torque of the actuator at controlling operation.

Control valve in straightway form with electric actuator FR 1.2 with fail-safe function

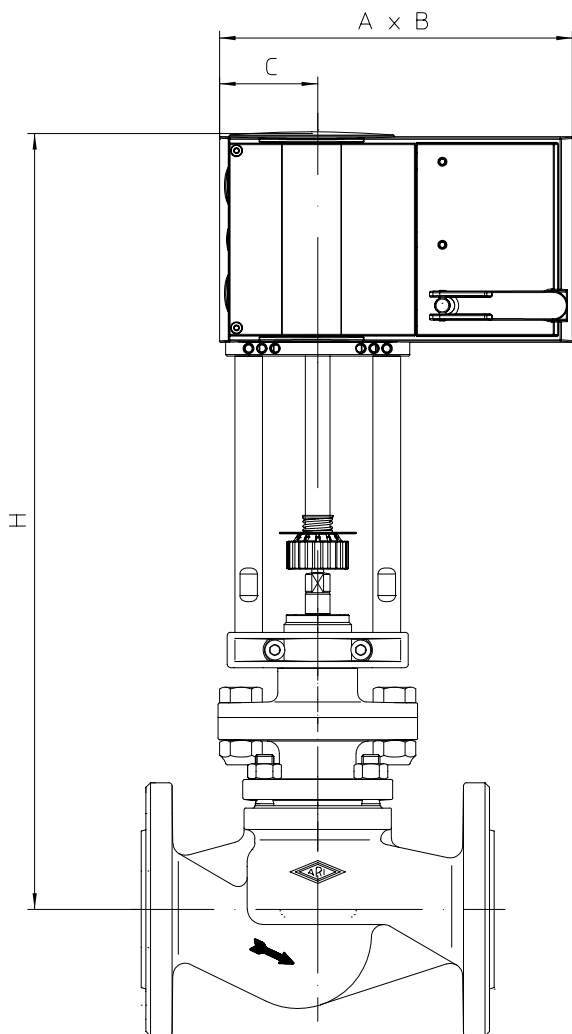

Fig. 440

Actuator data		FR 1.2
A	(mm)	230
B	(mm)	120
C	(mm)	64
Supply voltage: 24V 50/60Hz 1~, 24VDC, 230V 50/60Hz 1~ Technical data for actuator refer to data sheet FR1.2.		

Heights and weights

DN		15	20	25	32	40	50	65	80	100			
Fig. 440	FR 1.2	H	(mm)	502	502	510	510	517	523	536	551	570	
		Parabolic plug	PN16	(kg)	10	10	11	13	15	18	23	28	39
			PN40	(kg)	10	11	12	14	16	19	26	32	45
		Parabolic pressure balanced plug	PN16	(kg)	--	--	--	--	16	20	26	32	44
			PN40	(kg)	--	--	--	--	17	21	29	36	50

Other dimensions refer to pages 20-21.

max. permissible closing pressures on flow-to-open P2 = 0.
Observe pressure-temperature-limits, refer to page 2.

Fig. 440 Parabolic plug			15	20	25	32	40	50	65	80	100	
DN			15	20	25	32	40	50	65	80	100	
Parabolic plug	Kvs-value	(m ³ /h)	4 2,5	6,3 4 / 2,5	10 6,3	16 10	25 16	40 25	63 40	100 63	160 100	
	max. diff. pressure ¹⁾		(bar)	40	40	40	40	30	20	8	4	1,5
Seat-ø			(mm)	21	21	27	31	41	51	66	81	101
Travel			(mm)	20						30		
FR 1.2 2 kN	Closing pressure	I.	(bar)	40	40	27,5	20,6	11,3	7	3,8	2,3	1,3
	Operating time (factory setting)		(s)	40						60		
	Operating time on electrical power failure		(s)	28						35		

Fig. 440 Parabolic pressure balanced plug			15	20	25	32	40	50	65	80	100
DN			15	20	25	32	40	50	65	80	100
Parabolic plug	Kvs-value	(m ³ /h)					25 16	40 25	63 40	100 63	160 100
	max. diff. pressure ¹⁾		(bar)					30	20	8	4
Seat-ø			(mm)				41	51	66	81	101
Travel			(mm)				20		30		
FR 1.2 2 kN	Closing pressure	I.	(bar)				40	40	40	40	25
	Operating time (factory setting)		(s)				40		60		
	Operating time on electrical power failure		(s)				28		35		

I. Fig. 440: PTFE-V-ring unit (Medium temperature restricted to 200°C)

¹⁾ max. differential pressure drop

Control valve in straightway form with electric actuator FR 2.1 / FR 2.2

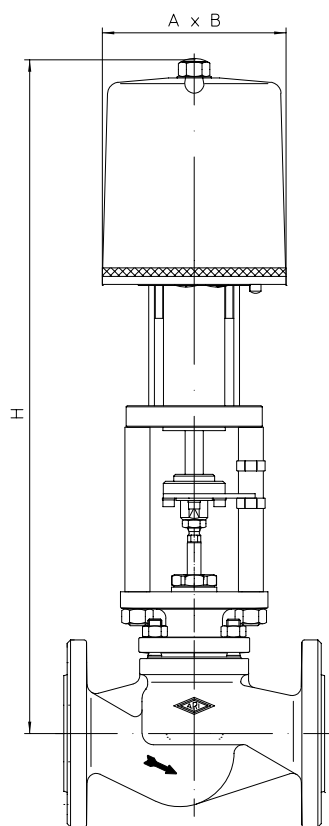

Fig. 440

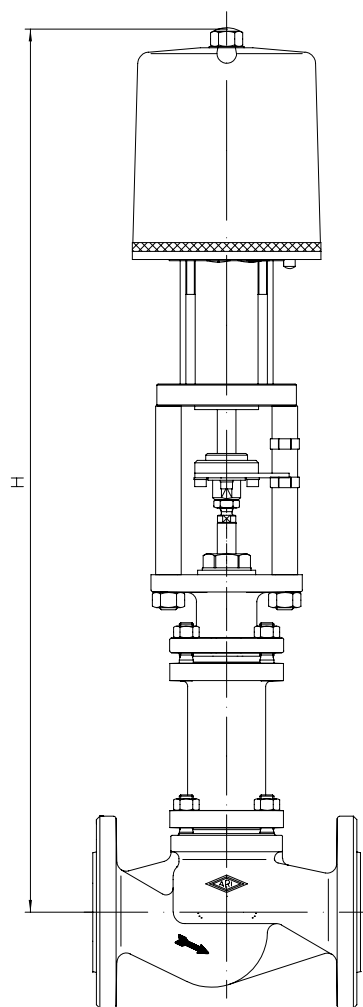

Fig. 441

Actuator data		FR 2.1 / 2.2
A	(mm)	162
B	(mm)	162

Supply voltage: 230V 50Hz
Other voltages: 24V 50/60Hz; 230V 60Hz
 Technical data for actuator refer to data sheet FR2.1/2.2

 Control valve Type 440 - FR 2.1 acc. to DIN 32730
 (EN-JL1040, EN-JS1049, 1.0619+N)

Heights and weights

DN		15	20	25	32	40	50	65	80	100			
Fig. 440	FR 2.1	H	(mm)	579	579	587	587	594	600	613	628	647	
			(mm)	616	616	624	624	631	637	650	665	684	
	FR 2.1	Parabolic plug	PN16	(kg)	12	13	14	16	17	20	25	31	41
			PN40	(kg)	13	14	15	16	19	22	29	35	47
	FR 2.2	Parabolic pressure balanced plug	PN16	(kg)	--	--	--	--	18	22	28	35	46
			PN40	(kg)	--	--	--	--	20	24	32	39	52
Fig. 441	FR 2.1	H	(mm)	764	764	772	772	763	765	849	861	877	
			(mm)	801	801	809	809	800	802	886	898	914	
	FR 2.1	Parabolic plug	PN16	(kg)	17	17	18	20	23	25	28	39	55
			PN40	(kg)	19	20	23	26	32	34	41	51	68
	FR 2.2	Parabolic pressure balanced plug	PN16	(kg)	--	--	--	--	24	27	31	43	60
			PN40	(kg)	--	--	--	--	33	36	44	55	73

Other dimensions refer to pages 20-21.

Fig. 440 / 441 Parabolic plug

DN			15	20	25	32	40	50	65	80	100	
Parabolic plug	Kvs-value	(m ³ /h)	4 2,5	6,3 4 / 2,5	10 6,3	16 10	25 16	40 25	63 40	100 63	160 100	
	max. diff. pressure ¹⁾	(bar)	40	40	40	40	30	20	8	4	1,5	
Seat-ø		(mm)	21	21	27	31	41	51	66	81	101	
Travel		(mm)	20						30			
FR 2.1 1 kN	Closing pressure	I.	(bar)	18	18	10,3	7,4	3,6	2			
		II.	(bar)	16	16	9	6,5	3,2	1,7			
		III.	(bar)	9	9	7,4	5,2	1,9	0,9			
	Operating time (50 Hz)		(s)	69								
	Operating speed		(mm/s)	0,29								
Operating time on electrical power failure		(s)	5,5									
FR 2.2 2,2 kN	Closing pressure	I.	(bar)	40	40	30,8	23,1	12,8	8	4,3	2,7	1,5
		II.	(bar)	40	40	28,8	21,6	11,9	7,4	3,9	2,3	1,3
		III.	(bar)	30,7	30,7	27,1	20,4	10,6	6,5	3,6	2,2	1,2
	Operating time (50 Hz)		(s)	69						103		
	Operating speed		(mm/s)	0,29								
Operating time on electrical power failure		(s)	5,5						8,5			

Fig. 440 / 441 Parabolic pressure balanced plug

DN			15	20	25	32	40	50	65	80	100	
Parabolic plug	Kvs-value	(m ³ /h)			10 6,3	16 10	25 16	40 25	63 40	100 63	160 100	
	max. diff. pressure ¹⁾	(bar)			40	40	30	20	8	4	1,5	
Seat-ø		(mm)			27	31	41	51	66	81	101	
Travel		(mm)	20						30			
FR 2.1 1 kN	Closing pressure	I.	(bar)			20	20	20	16	16	16	12
		II.	(bar)					20	16	16		
		III.	(bar)					16	15	2		
	Operating time (50 Hz)		(s)			69						103
	Operating speed		(mm/s)			0,29						
Operating time on electrical power failure		(s)			5,5						8,5	
FR 2.2 2,2 kN	Closing pressure	I.	(bar)					40	40	40	40	28
		II.	(bar)					40	40	40	40	28
		III.	(bar)					40	40	40	40	40
	Operating time (50 Hz)		(s)					69		103		
	Operating speed		(mm/s)					0,29				
Operating time on electrical power failure		(s)					5,5		8,5			

 Control valve Type 440 - FR 2.1 acc. to DIN 32730
 (EN-JL1040, EN-JS1049, 1.0619+N)

- I. Fig. 440: PTFE-V-ring unit / EPDM-sealing
- II. Fig. 440: PTFE- / pure graphite-packing
- III. Fig. 441: Bellows seal

¹⁾ max. differential pressure drop

Control valve in straightway form

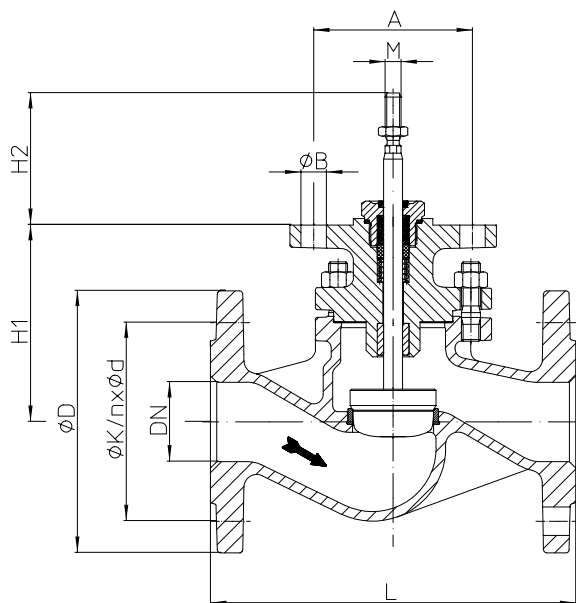
Fig. 440

DN15-150

(e.g. DP32-34, PREMIO 2-15kN, AUMA SAR 07.2-10.2)

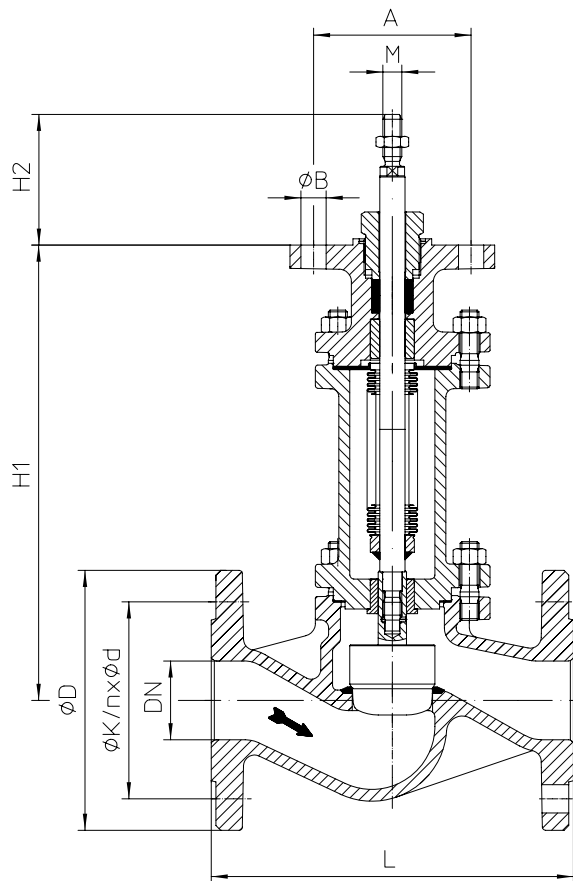
Fig. 441

DN15-150

(e.g. DP32-34, PREMIO 2-15kN, AUMA SAR 07.2-10.2)

DN	15	20	25	32	40	50	65	80	100	125	150
----	----	----	----	----	----	----	----	----	-----	-----	-----

Dimensions													
M	Fig. 440	(mm)	M10				M14 x 1,5				M16 x 1,5		
	Fig. 441	(mm)	M12								M16		
H1	Fig. 440	(mm)	103	111	118	124	137	152	171	210	270		
	Fig. 441	(mm)	288	296	287	289	373	385	401	565	596		
H2	Fig. 440 / Fig. 441	(mm)	83										
A	Fig. 440 / Fig. 441	(mm)	100										
n x ØB	Fig. 440 / Fig. 441	(mm)	2 x 16										

Face-to-face dimension FTF series 1 according to DIN EN 558												
L	(mm)	130	150	160	180	200	230	290	310	350	400	480

Flanges acc. to DIN EN 1092-1/-2			Flange holes / -thickness tolerances acc. to DIN 2533/2544/2545											
ØD	PN16	(mm)	95	105	115	140	150	165	185	200	220	250	285	
	PN25	(mm)									235	270	300	
	PN40	(mm)												
ØK	PN16	(mm)	65	75	85	100	110	125	145	160	180	210	240	
	PN25	(mm)									190	220	250	
	PN40	(mm)												
n x Ød	PN16	(mm)	4 x 14	4 x 14	4 x 18	4 x 18	4 x 18	4 x 18	8 x 18	8 x 18	8 x 18		8 x 22	
	PN25	(mm)									8 x 22		8 x 26	8 x 26
	PN40	(mm)												

Weights													
Fig. 440	PN16 (JL1040)	(kg)	3,6	4,3	5,2	6,8	8,7	11,6	16,7	22,4	32,5	49,7	72,9
	PN40 (1.0619+N)	(kg)	4,3	5,2	6,1	7,5	10	13	20	26	38,7	55,9	77,2
Fig. 441	PN16 (JL1040)	(kg)	8	8	9	11,5	14	16,5	19,5	30,5	46	65,8	87,2
	PN40 (1.0619+N)	(kg)	10	11,5	14	17	23	25,5	32,5	42,5	59	76,3	92,7

max. permissible thrust													
Fig. 440	(kN)		12,7				29,6				40,6		
Fig. 441	(kN)		18,2										37

Control valve in straightway form

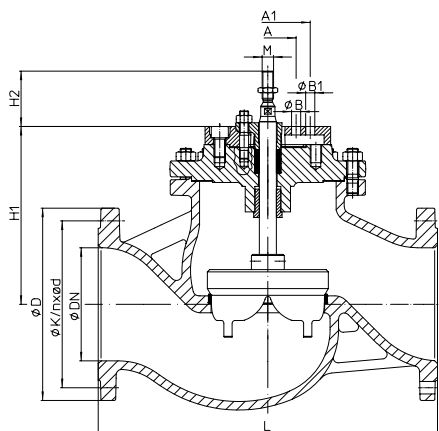
Fig. 440
DN200-250

(e.g. DP34-34Tri, PREMIO 12-15kN)

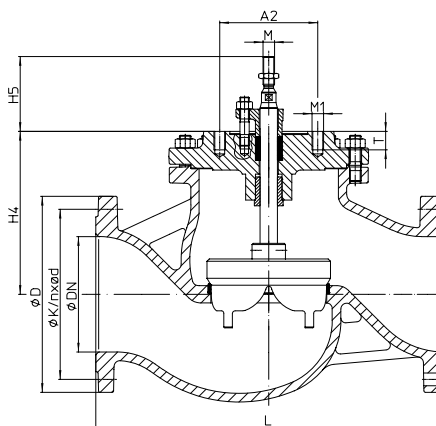
Fig. 440
DN200-250

(e.g. AUMA SAR 07.2-10.2)

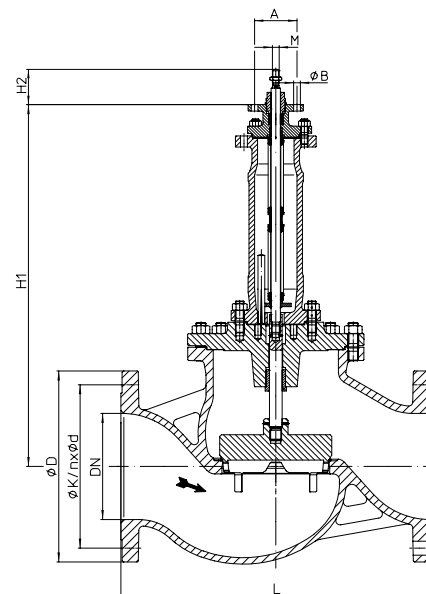
Fig. 441 M16
DN200-250

(e.g. PREMIO 12-15kN, AUMA SAR 07.2-10.2)

DN	200	250
----	-----	-----

Dimensions						
M	Fig. 440	(mm)	M20			
	Fig. 441	(mm)	M16	M20	M16	M20
H1	Fig. 440	(mm)	312			
	Fig. 441	(mm)	792	723	856	782
H2	Fig. 440	(mm)	98			
	Fig. 441	(mm)	83	130	83	130
H4	Fig. 440	(mm)	280		340	
H5	Fig. 440	(mm)	130			
A	Fig. 440	(mm)	100			
	Fig. 441	(mm)	100	--	100	--
n x ØB	Fig. 440	(mm)	2 x 16			
	Fig. 441	(mm)	2 x 16	--	2 x 16	--
A1	Fig. 440	(mm)	150			
	Fig. 441	(mm)	--	150	--	150
n x ØB1	Fig. 440	(mm)	4 x 16			
	Fig. 441	(mm)	-	4 x 16	--	4 x 16
A2	Fig. 440	(mm)	170			
n x M1	Fig. 440	(mm)	8 x M20			
T	Fig. 440	(mm)	32			

Face-to-face dimension FTF series 1 according to DIN EN 558				
L	(mm)	600	730	

Flanges acc. to DIN EN 1092-1/-2				
ØD	PN16	(mm)	340	405
	PN25	(mm)	360	425
	PN40	(mm)	375	450
ØK	PN16	(mm)	295	355
	PN25	(mm)	310	370
	PN40	(mm)	320	385
n x Ød	PN16	(mm)	12x22	12x26
	PN25	(mm)	12x26	12x30
	PN40	(mm)	12x30	12x33

Weights						
Fig. 440	PN16 (JL1040)	(kg)	145	259,3		
	PN40 (1.0619+N)	(kg)	176,8	291,4		
Fig. 441	PN16 (JL1040)	(kg)	158,1	167,2	282,2	281,3
	PN40 (1.0619+N)	(kg)	203,6	202	318,1	316,5

max. permissible thrust		
Fig. 440	(kN)	59,1
Fig. 441	(kN)	34

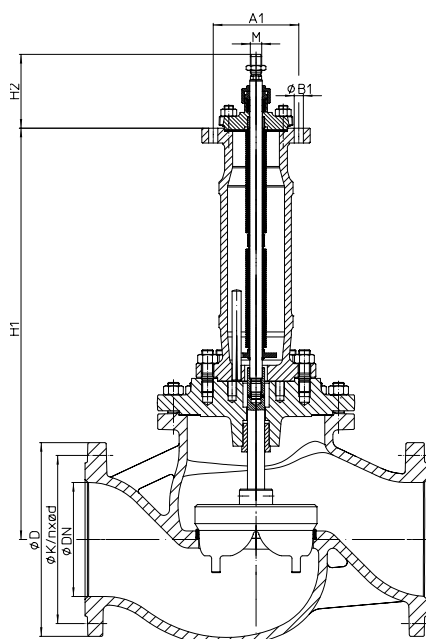
Fig. 441 M20
DN200-250

(e.g. DP34-34Tri)

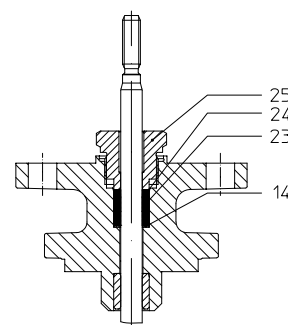
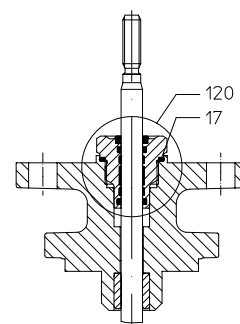
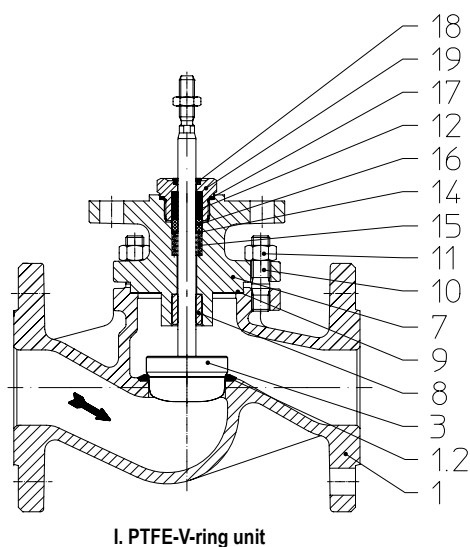

Pos.	Sp.p.	Description	Fig. 12.440	Fig. 22.440 / Fig. 23.440	Fig. 34.440 / Fig. 35.440	Fig. 54.440 / 55.440
1		Body	EN-GJL-250 , EN-JL 1040	EN-GJS-400-18U-LT, EN-JS1049	GP240GH+N, 1.0619+N	GX5CrNiMo19-11-2, 1.4408
1.2		Seat ring	X20Cr13+QT, 1.4021+QT		X20Cr13+QT, 1.4021+QT >DN50: G19 9 Nb Si, 1.4551	--
3	x	Plug	X20Cr13+QT, 1.4021+QT			X6CrNiMoTi17-12-2, 1.4571
7		Mounting bonnet	EN-GJS-400-18U-LT, EN-JS1049		GP240GH+N, 1.0619+N	GX5CrNiMo19-11-2, 1.4408
8		Guide bushing	X20Cr13+QT, 1.4021+QT (hardened)			X6CrNiMoTi17-12-2, 1.4571
9	x	Gasket	Pure graphite (CrNi laminated with graphite)			
10		Stud	25CrMo4, 1.7218			A4 - 70
11		Hexagon nuts	C35E, 1.1181			A4
12	Set. refer to Pos. 100	V-ring unit	PTFE			
14		Washer	X5CrNi18-10, 1.4301			
15		Compression spring	X10CrNi18-8, 1.4310			
16		Bush	PTFE (strengthened)			
17		Gasket	Cu / Soft iron			
18		Scraper	PTFE (strengthened)			
19		Coupling	X8CrNiS18-9, 1.4305			
23/24	x	Packing ring	PTFE or Pure graphite			
25	x	Coupling	X8CrNiS18-9, 1.4305			

Stem sealings Fig. 440

23	x	Packing ring	PTFE
23/24	x	Packing ring	Pure graphite
100	x	V-ring unit set	Set of: Pos. 12, 14, 15, 16, 17, 18, 19
120	x	EPDM-sealing	EPDM / X8CrNiS18-9, 1.4305 (when spare part, also necessary: Pos. 17)
		L Spare parts	

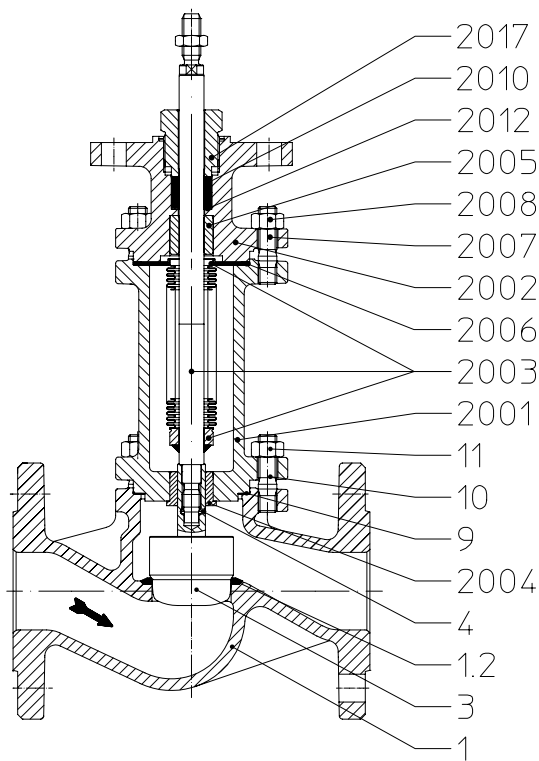

III. PTFE-packing / Pure graphite-packing

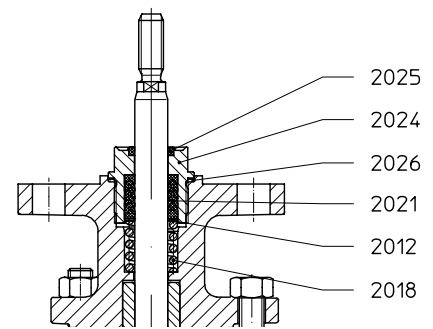

III. Stainless steel-bellows with V-ring unit

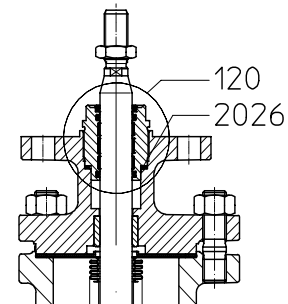

III. Stainless steel bellows seal with EPDM-sealing

Pos.	Sp.p.	Description	Fig. 12.441	Fig. 22.441 / Fig. 23.441	Fig. 34.441 / Fig. 35.441	Fig. 55.441	
1		Body	EN-GJL-250 , EN-JL1040	EN-GJS-400-18U-LT, EN-JS1049	GP240GH+N, 1.0619+N	GX5CrNiMo19-11-2, 1.4408	
1.2		Seat ring	X20Cr13+QT, 1.4021+QT		X20Cr13+QT, 1.4021+QT >DN50: G19 9 Nb Si, 1.4551	--	
3	x	Plug	X20Cr13+QT, 1.4021+QT			X6CrNiMoTi17-12-2, 1.4571	
4	x	Clamping sleeve	X10CrNi18-8, 1.4310			A4 - 70	
9	x	Gasket	Pure graphite (CrNi laminated with graphite)				
10		Stud	25CrMo4, 1.7218			A4 - 70	
11		Hexagon nuts	C35E, 1.1181			A4	
2001		Bellows housing	EN-GJS-400-18U-LT, EN-JS1049		GP240GH+N, 1.0619+N	GX5CrNiMo19-11-2, 1.4408	
2002		Mounting bonnet	EN-GJS-400-18U-LT, EN-JS1049		GP240GH+N, 1.0619+N	GX5CrNiMo19-11-2, 1.4408	
2003	x	Stem- / Bellows unit	X20Cr13+QT, 1.4021+QT / X6CrNiTi18-10, 1.4541			X6CrNiMoTi17-12-2, 1.4571	
2004		Guide bushing	X20Cr13+QT, 1.4021+QT (hardened)			X6CrNiMoTi17-12-2, 1.4571	
2005		Guide bushing	X20Cr13+QT, 1.4021+QT (hardened)			X6CrNiMoTi17-12-2, 1.4571	
2006	x	Gasket	Pure graphite (CrNi laminated with graphite)				
2007		Stud	25CrMo4, 1.7218			A4 - 70	
2008		Hexagon nuts	C35E, 1.1181			A4	
2010	x	Packing ring	Pure graphite				
2012	Set: refer to Pos. 100	Washer	X5CrNi18-10, 1.4301				
2018		Compression spring	X10CrNi18-8, 1.4310				
2021		V-ring unit	PTFE				
2024		Coupling	X8CrNiS18-9, 1.4305				
2025		Scraper	PTFE				
2026		Gasket	X6CrNiMoTi17-12-2, 1.4571				
2017			Coupling	X8CrNiS18-9, 1.4305			

Stem sealings Fig. 441

2010	x	Packing ring	Pure graphite
2010	x	Packing ring	PTFE
100	x	V-ring unit set	Set of: Pos. 2012 - 2226
120	x	EPDM-sealing	EPDM / X8CrNiS18-9, 1.4305 (when spare part, also necessary: Pos. 2031)
		L Spare parts	

myValve® - Your Valve Sizing-Program.

myValve® is a powerful software tool that not only helps you size your system components; it also gives you instant access to all other data about the selected product, such as order information, spare parts drawings, operating instructions, data sheets, etc., whenever you need it.



Contents:

Module ARI-control valves STEVI-calculation

- Sizing (calculation of flow quantity Kv, volume flow Q, pressure drop Δp , sound level and selecting the valve.)

Media:

Integrated media-databank (more than 160 media) with conditions:

- Vapours / gases
- Steam (saturated and superheated)
- Liquids

Special features:

- Project administration of the calculation and product data incl. spare part drawings concerning to project and tag number.
- Direct output or calculation and product data in PDF format.
- Product data could be taken for a direct order.
- SI- and ANSI-units with direct conversion to another databank.
- Settings with over pressure or absolute pressure.
- All ARI valves are integrated in a databank.
- Direct access concerning to the product on data sheets, operating instructions, pressure-temperature-diagram and spare part drawings
- Operation in company networks possible (no complex installations on individually PC's necessary).
- Extensive catalogue extending over several product groups.

System Requirements:

Windows operating systems, Linux, etc.



Technology for the Future.
GERMAN QUALITY VALVES

ARI-Armaturen Albert Richter GmbH & Co. KG, D-33750 Schloß Holte-Stukenbrock,
Tel. +49 52 07 / 994-0, Telefax +49 52 07 / 994-158 or 159 Internet: <http://www.ari-armaturen.com> E-mail: info.vertrieb@ari-armaturen.com